

- MODEL 1003-1695
- MODEL 1003-7335
- MODEL 1003-1296
- MODEL 1003-6497
- MODEL 1003-1297
- MODEL 1003-7336
- MODEL 1003-1298

A:	SUB FOR:	WEIGHT:
5 7/8" / 149.23 MM	PENZ 03-207-H	2.75 LBS / 1.25 Kg
7 5/8" / 193.68 MM	PENZ 03-209-H	2.84 LBS / 1.28 Kg
9 5/8" / 244.48 MM	PENZ 03-211-H	3.28 LBS / 1.49 Kg
11" / 279.4 MM	PENZ 03-212-H	3.20 LBS / 1.45 Kg
14 1/2" / 368 MM	PENZ 03-215-H	3.39 LBS / 1.54 Kg
16 1/8" / 409.58 MM	PENZ 03-217-H	3.42 LBS / 1.55 Kg
19 5/8" / 498.48 MM	PENZ 03-221-H	3.82 LBS / 1.73 Kg

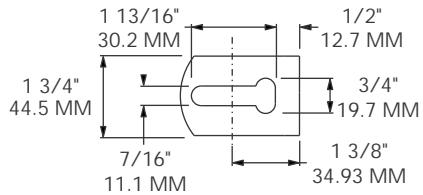

MATERIAL: 1 1/4" O.D. x 14 GA. TUBING
FINISH: PRIMER

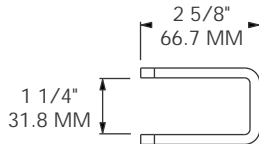
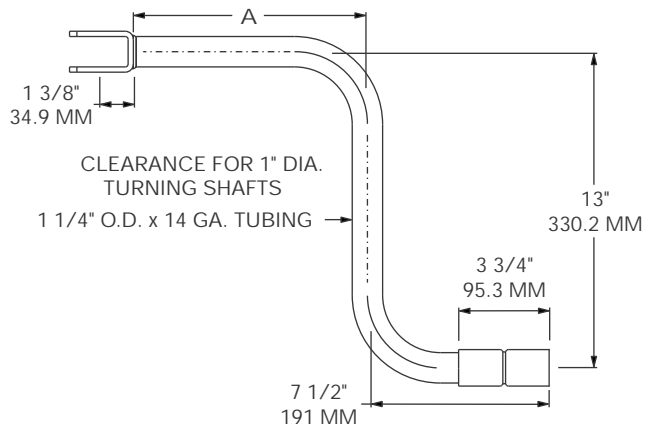

CRANK HANDLES VERTICAL BRACKET TYPE

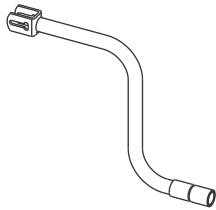

- MODEL 1003-1664**
- MODEL 1003-1764**
- MODEL 1003-1365**
- MODEL 1003-2439**
- MODEL 1003-1366**
- MODEL 1003-1367**

A:	SUB FOR:	WEIGHT:
5 7/8" / 149.23 MM	PENZ 03-207-V	2.75 LBS / 1.25 Kg
7 5/8" / 193.68 MM	PENZ 03-209-V	2.9 LBS / 1.32 Kg
9 5/8" / 244.48 MM	PENZ 03-211-V	3.3 LBS / 1.49 Kg
12 1/8" / 308 MM	PENZ 03-213-V	3.5 LBS / 1.59 Kg
14 1/2" / 368 MM	PENZ 03-215-V	3.39 LBS / 1.54 Kg
19 5/8" / 498.48 MM	PENZ 03-221-V	4.01 LBS / 1.82 Kg

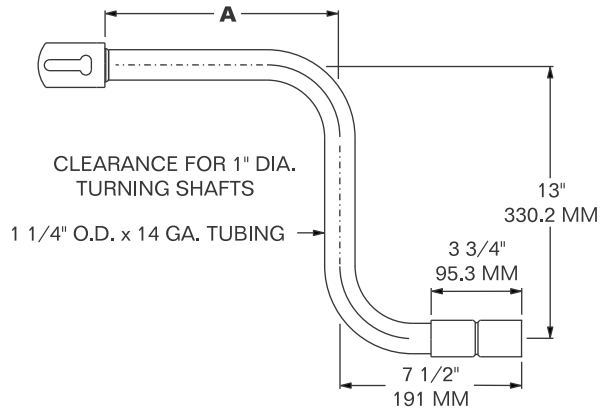
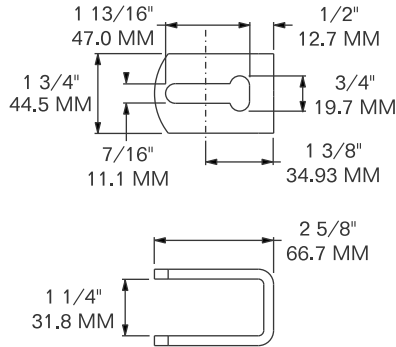

MATERIAL: 1 1/4" O.D. x 14 GA. TUBING
FINISH: PRIMER

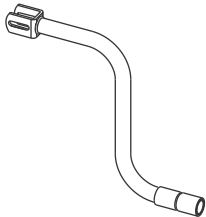

- MODEL 1003-6857**
- MODEL 1003-6858**
- MODEL 1003-6859**
- MODEL 1003-6863**
- MODEL 1003-6430**

A:	SUB FOR:	WEIGHT:
9 1/8" / 231.7 MM	HOLLAND XA-V-90-0	3.6 LBS / 1.63 Kg
11 5/8" / 295.2 MM	HOLLAND XA-V-90-2	3.8 LBS / 1.72 Kg
14 1/2" / 368.3 MM	HOLLAND XA-V-90-5	4.04 LBS / 1.83 Kg
17" / 431.8 MM	HOLLAND XA-V-90-10	4.26 LBS / 1.93 Kg
19" / 482.6 MM	HOLLAND XA-V-90-11	4.4 LBS / 2.0 Kg

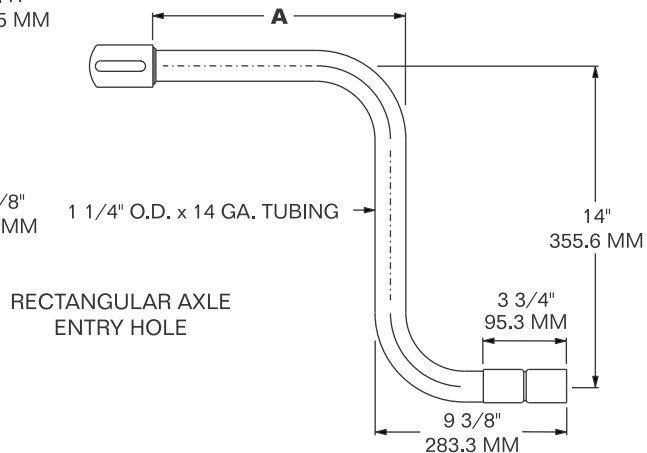
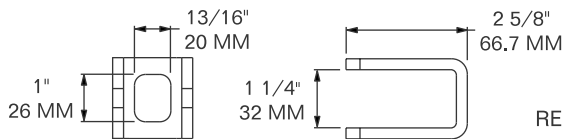
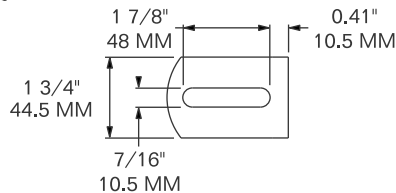

MATERIAL: 1 1/4" O.D. x 14 GA. TUBING
FINISH: PRIMER

MODEL 1003-1406

CRANK HANDLE KEEPER

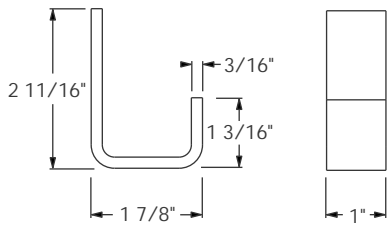
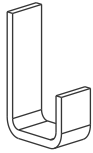

SUB FOR: PENZ 03-403
 MATERIAL: FAB STEEL FINISH: PRIMER
 WEIGHT: 0.27 LBS / 0.12 Kg

MODEL 1003-1789

CRANK HANDLE KEEPER

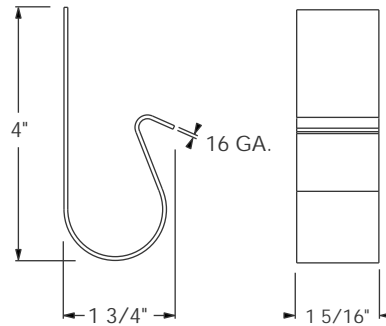
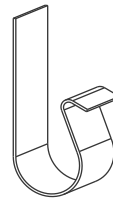

SUB FOR: PENZ 03-400, HOLLAND XA-V-1914
 MATERIAL: SPRING STEEL FINISH: PRIMER
 WEIGHT: 0.21 LBS / 0.1 Kg