

ALUMINUM CORNER CAPS

1300

MODEL 1303-2062-CS

CURBSIDE

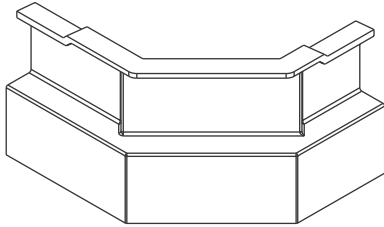

SUB FOR: HYUNDAI 10004168,
MONON V02-197-R

MODEL 1303-2062-RS

ROADSIDE

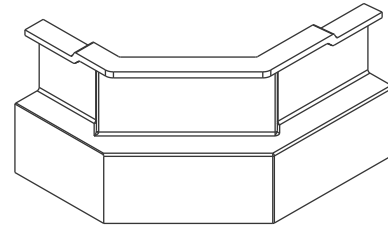

SUB FOR: HYUNDAI 10004167,
MONON V02-198-L

MATERIAL: CAST ALUMINUM
FINISH: SELF-COLOR
WEIGHT: 2.60 LBS / 1.18 Kg

MODEL 1303-2063

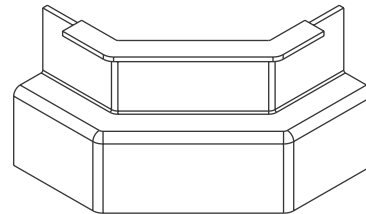

SUB FOR: MILLER 044-090200
MATERIAL: CAST ALUMINUM
FINISH: SELF-COLOR
WEIGHT: 2.1 LBS / 0.95 Kg

MODEL 1303-2065

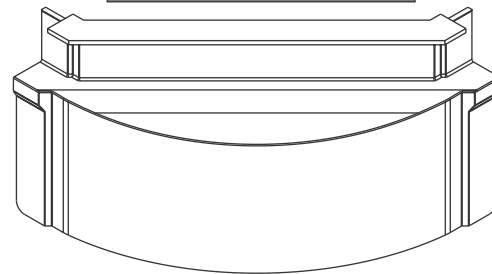

SUB FOR: LUFKIN 10" 60113
MATERIAL: CAST ALUMINUM
FINISH: SELF-COLOR
WEIGHT: 3.95 LBS / 1.79 Kg

MODEL 1303-2066

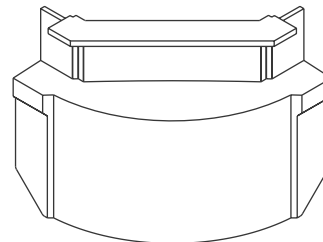

SUB FOR: LUFKIN 6" 65278
MATERIAL: CAST ALUMINUM
FINISH: SELF-COLOR
WEIGHT: 2.60 LBS / 1.18 Kg



ALUMINUM CORNER CAPS

1300

MODEL 1303-2067-CS

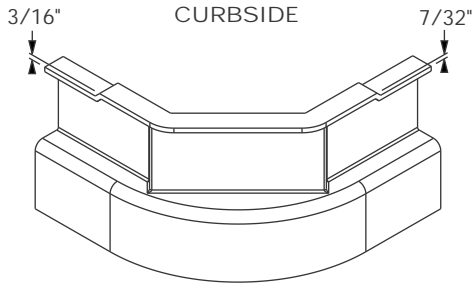

SUB FOR: HYUNDAI 10012219 RH

MODEL 1303-2067-RS

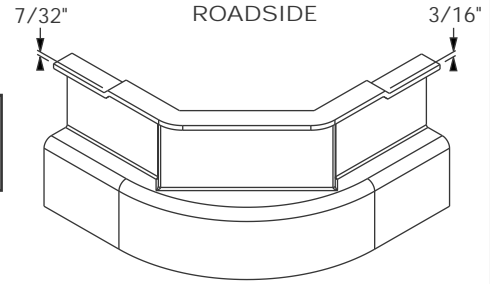

SUB FOR: HYUNDAI 10012220 LH

MATERIAL: CAST ALUMINUM
FINISH: SELF-COLOR
WEIGHT: 2.75 LBS / 1.25 Kg

MODEL 1303-2068-CS

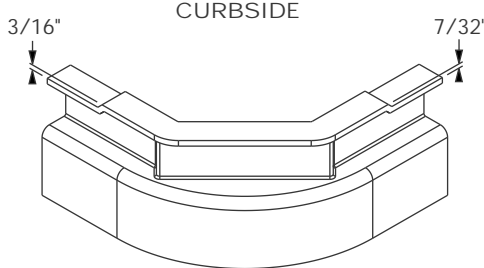

SUB FOR: HYUNDAI 10013434 RH

MODEL 1303-2068-RS

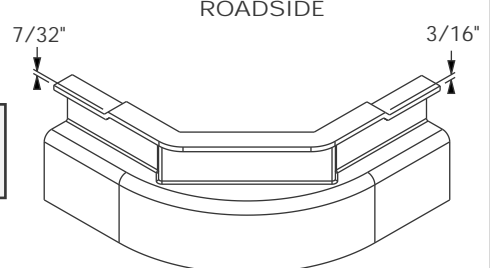

SUB FOR: HYUNDAI 10013435 LH

MATERIAL: CAST ALUMINUM
FINISH: SELF-COLOR
WEIGHT: 2.5 LBS / 1.13 Kg

MODEL 1303-2069

SUB FOR: PINES CCB7177
MATERIAL: CAST ALUMINUM
FINISH: SELF-COLOR
WEIGHT: 1.85 LBS / 0.84 Kg

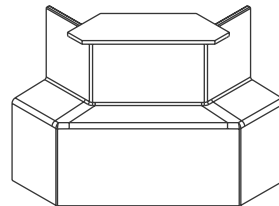

MODEL 1303-2070

SUB FOR: PINES CC11100
MATERIAL: CAST ALUMINUM
FINISH: SELF-COLOR
WEIGHT: 1.75 LBS / 0.79 Kg

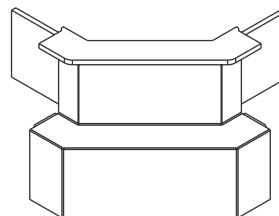

MODEL 1303-2071

SUB FOR: STRICK GA65D-003-01-00
 MATERIAL: CAST ALUMINUM
 FINISH: SELF-COLOR
 WEIGHT: 2.75 LBS / 1.24 Kg

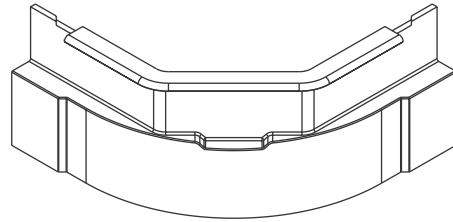

MODEL 1303-2072

SUB FOR: MONON A1042138
 MATERIAL: CAST ALUMINUM
 FINISH: SELF-COLOR
 WEIGHT: 2.40 LBS / 1.09 Kg

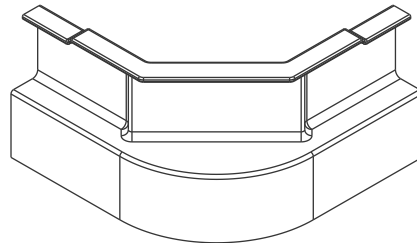

MODEL 1303-2073

SUB FOR: STOUGHTON 04-12835
 MATERIAL: CAST ALUMINUM
 FINISH: SELF-COLOR
 WEIGHT: 4.07 LBS / 1.85 Kg

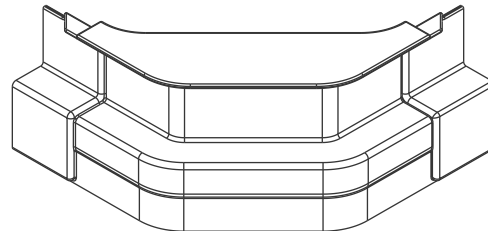

MODEL 1303-2074-CS

CURBSIDE

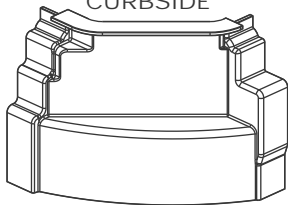

SUB FOR: UTILITY 1-1550-0-033-RH
 FITS: DUAL AXLE 2000D TRAILER

MODEL 1303-2074-RS

ROADSIDE

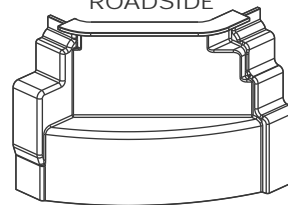

SUB FOR: UTILITY 1-1550-0-032-LH
 FITS: DUAL AXLE 2000D TRAILER

MATERIAL: CAST ALUMINUM
 FINISH: SELF-COLOR
 WEIGHT: 1.9 LBS / 0.86 Kg



1300

MODEL 1303-2075

SUB FOR: HYUNDAI 10014978
MATERIAL: CAST ALUMINUM
FINISH: SELF-COLOR
WEIGHT: 2.6 LBS / 1.18 Kg

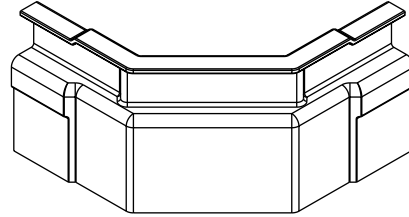

MODEL 1303-2076

SUB FOR: HYUNDAI 10015378
MATERIAL: CAST ALUMINUM
FINISH: SELF-COLOR
WEIGHT: 2.77 LBS / 1.26 Kg

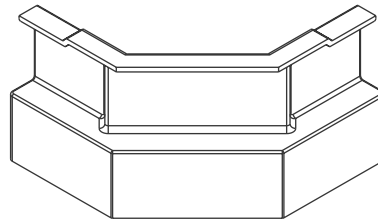

MODEL 1303-2077

SUB FOR: HYUNDAI 10015416
MATERIAL: CAST ALUMINUM
FINISH: SELF-COLOR
WEIGHT: 3.0 LBS / 1.36 Kg

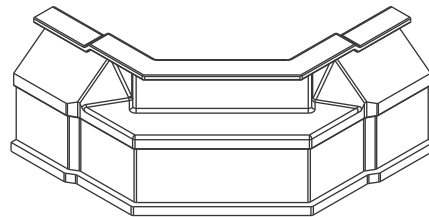

MODEL 1303-2078

SUB FOR: HYUNDAI 10016167
MATERIAL: CAST ALUMINUM
FINISH: SELF-COLOR
WEIGHT: 2.98 LBS / 1.35 Kg

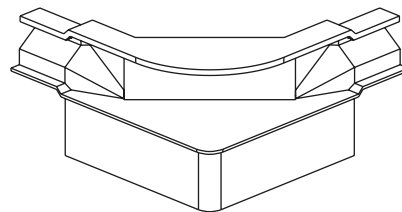

MODEL 1303-2079-CS

CURBSIDE

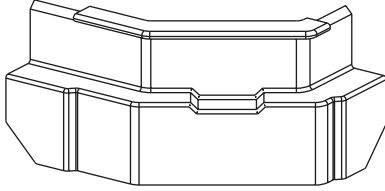

MATERIAL: CAST ALUMINUM
FINISH: SELF-COLOR
WEIGHT: 2.2 LBS / 1.0 Kg

SUB FOR: STRICK AA65D-0023-02-00 (CS)

MODEL 1303-2079-RS

ROADSIDE

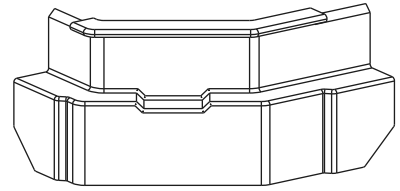

SUB FOR: STRICK AA65D-0024-02-00 (RS)

MODEL 1303-2080

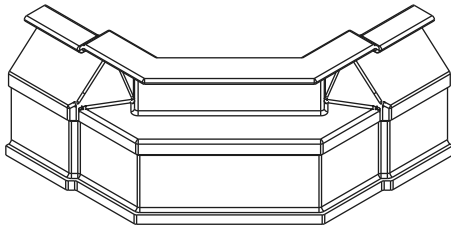

SUB FOR: HYUNDAI 10015416
MATERIAL: CAST ALUMINUM
FINISH: SELF-COLOR
WEIGHT: 2.90 LBS / 1.32 Kg

MODEL 1303-2081

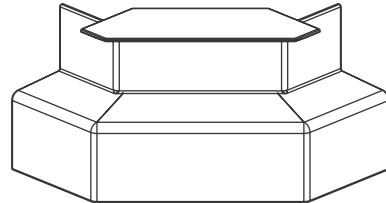

SUB FOR: GREAT DANE 69102183
MATERIAL: CAST ALUMINUM
FINISH: SELF-COLOR
WEIGHT: 1.98 LBS / 0.90 Kg

MODEL 1303-2082

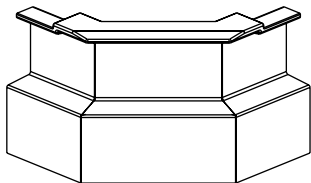

SUB FOR: WABASH 04-30002
MATERIAL: CAST ALUMINUM
FINISH: SELF-COLOR
WEIGHT: 2.00 LBS / 0.91 Kg

MODEL 1303-2083

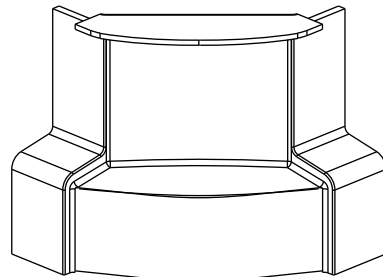

SUB FOR: TRAILMOBILE 7511-A1-05
MATERIAL: CAST ALUMINUM
FINISH: SELF-COLOR
WEIGHT: 1.24 LBS / 0.56 Kg

1300

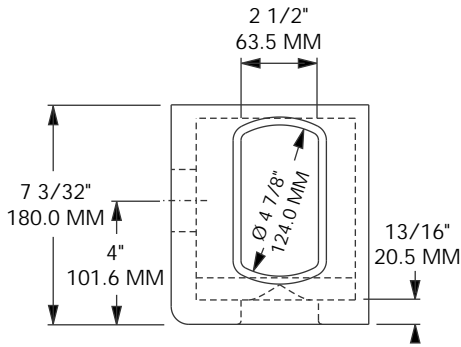

MODEL 6201-1142-TL

MODEL 6201-1142-TR

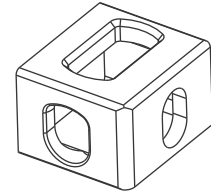
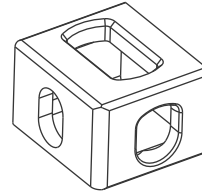

MODEL 6201-1142-TL
TOP LEFT

MODEL 6201-1142-TR
TOP RIGHT

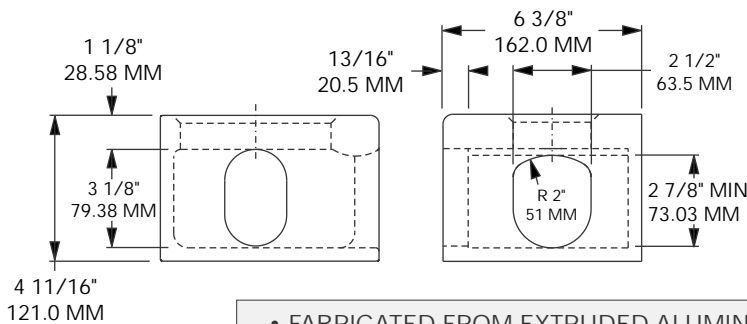

MATERIAL: ALUMINUM AL-ZN5-Mg1
FINISH: AS MACHINED
WEIGHT: 9.9 LBS / 4.5 Kg

- FABRICATED FROM EXTRUDED ALUMINUM CHANNELS.
- MACHINED ON ALL 6 SIDES FOR CLOSE TOLERANCE.
- LIGHT WEIGHT 9.9 LBS PER FITTING.
- MEETS ALL SIZE AND STRENGTH REQUIREMENTS OF ISO 1161.

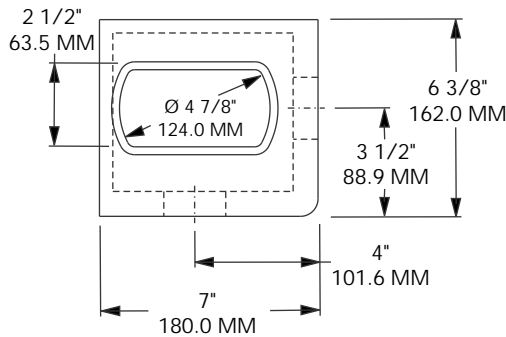

MODEL 6201-1142-BL

MODEL 6201-1142-BR

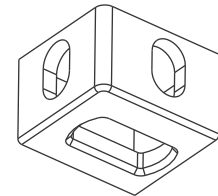
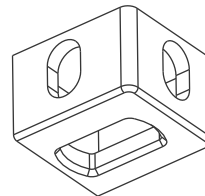

MODEL 6201-1142-BL
BOTTOM LEFT

MODEL 6201-1142-BR
BOTTOM RIGHT

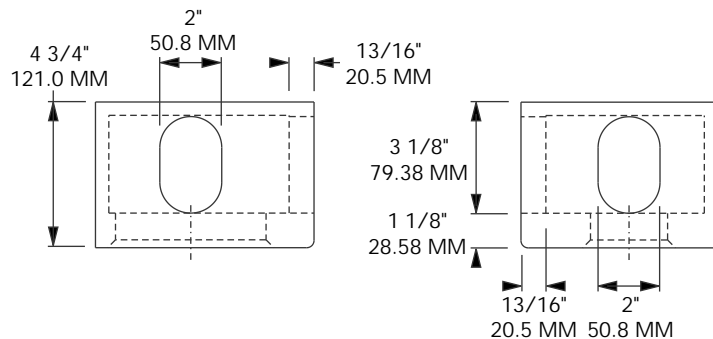

MATERIAL: ALUMINUM AL-ZN5-Mg1
FINISH: AS MACHINED
WEIGHT: 9.9 LBS / 4.5 Kg

