

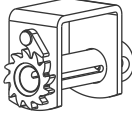
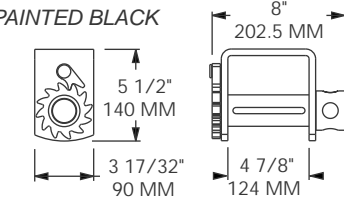
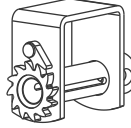
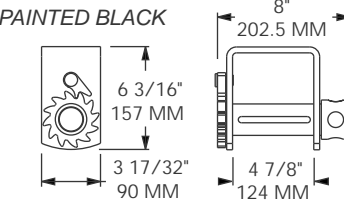
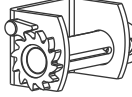
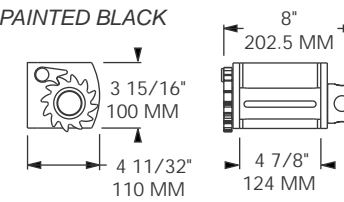
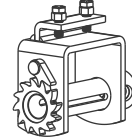
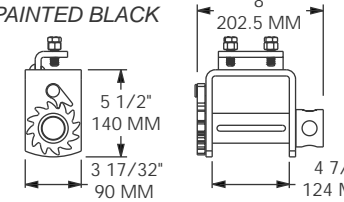
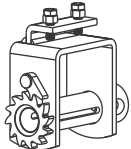
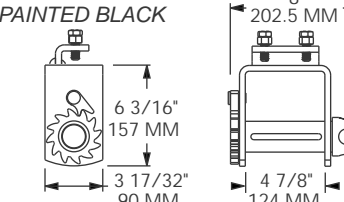
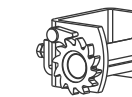
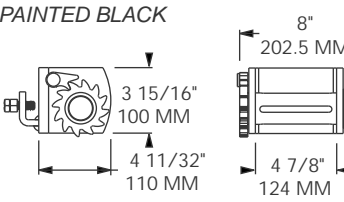
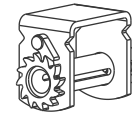
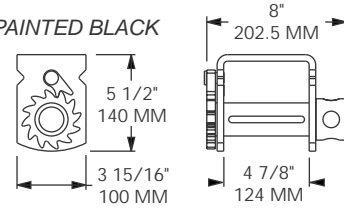

<p>MODEL 2903-2691</p> <p>WELD ON STANDARD</p>  <p>PAINTED BLACK</p>  <p>5 1/2" 140 MM 3 17/32" 90 MM 8" 202.5 MM 4 7/8" 124 MM</p>	<p>MODEL 2903-2692</p> <p>WELD ON STORAGE</p>  <p>PAINTED BLACK</p>  <p>6 3/16" 157 MM 3 17/32" 90 MM 8" 202.5 MM 4 7/8" 124 MM</p>	<p>MODEL 2903-2693</p> <p>WELD ON SIDE MOUNT</p>  <p>PAINTED BLACK</p>  <p>3 15/16" 100 MM 4 11/32" 110 MM 8" 202.5 MM 4 7/8" 124 MM</p>
<p>SUB FOR: ANCRA 43563-10, KINEDYNE 1820, MULTIPRENS 1160 WEIGHT: 8.25 LBS / 3.74 Kg</p>	<p>SUB FOR: ANCRA 43573-10, KINEDYNE 1820S WEIGHT: 8.85 LBS / 4.01 Kg</p>	<p>SUB FOR: ANCRA 43579-20, KINEDYNE 7820, MULTIPRENS 1165 WEIGHT: 7.54 LBS / 3.42 Kg</p>
<p>MODEL 2903-2694</p> <p>BOLT ON STANDARD</p>  <p>PAINTED BLACK</p>  <p>5 1/2" 140 MM 3 17/32" 90 MM 8" 202.5 MM 4 7/8" 124 MM</p>	<p>MODEL 2903-2695</p> <p>BOLT ON STORAGE</p>  <p>PAINTED BLACK</p>  <p>6 3/16" 157 MM 3 17/32" 90 MM 8" 202.5 MM 4 7/8" 124 MM</p>	<p>MODEL 2903-2696</p> <p>BOLT ON SIDE MOUNT</p>  <p>PAINTED BLACK</p>  <p>3 15/16" 100 MM 4 11/32" 110 MM 8" 202.5 MM 4 7/8" 124 MM</p>
<p>SUB FOR: ANCRA 43564-14, KINEDYNE 1820 P2, MULTIPRENS 1660 WEIGHT: 8.95 LBS / 4.06 Kg</p>	<p>SUB FOR: ANCRA 43564-12 WEIGHT: 9.95 LBS / 4.51 Kg</p>	<p>SUB FOR: ANCRA 43564-16, KINEDYNE 7820 P2, MULTIPRENS 1665 WEIGHT: 9.30 LBS / 4.22 Kg</p>
<p>MODEL 2903-2697</p> <p>SLIDER STANDARD</p>  <p>PAINTED BLACK</p>  <p>5 1/2" 140 MM 3 15/16" 100 MM 8" 202.5 MM 4 7/8" 124 MM</p>	<p>MODEL 2903-2698</p> <p>SLIDER STORAGE</p>  <p>PAINTED BLACK</p>  <p>6 7/8" 175 MM 3 15/16" 100 MM 8" 202.5 MM 4 7/8" 124 MM</p>	<p>MODEL 2903-2699</p> <p>SLIDER DEEP STORAGE</p>  <p>PAINTED BLACK</p>  <p>7 15/32" 190 MM 3 15/16" 100 MM 8" 202.5 MM 4 7/8" 124 MM</p>
<p>SUB FOR: ANCRA 43565-15, KINEDYNE 3820, MULTIPRENS 1760 WEIGHT: 8.20 LBS / 3.72 Kg</p>	<p>WEIGHT: 11.00 LBS / 4.99 Kg</p>	<p>SUB FOR: ANCRA 43565-12, KINEDYNE 5820, MULTIPRENS 1765 WEIGHT: 10.60 LBS / 4.81 Kg</p>

2900

NOTE: FOR LOAD SECURING ONLY, NOT FOR LIFTING.
ALL WINCH AND STRAP ASSEMBLIES SHOULD BE
INSPECTED FOR FRAYS, CUTS, OR DAMAGED
HARDWARE BEFORE AND AFTER USING.

WORKING LOAD LIMIT (WLL): 5,000 LBS / 2,267 Kg
BREAK STRENGTH (BS): 15,000 LBS / 6,800 Kg
DESIGNED TO MEET OR EXCEED WSTDA T-3 STANDARD.

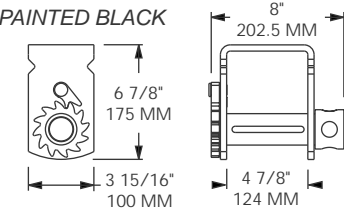
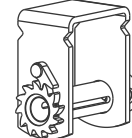
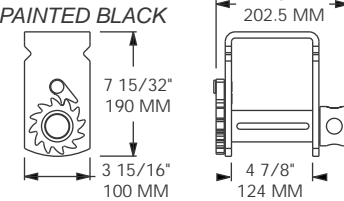

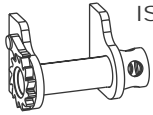
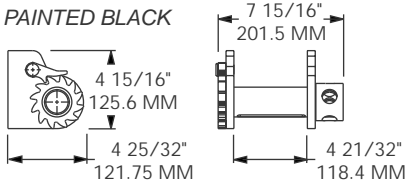
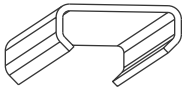
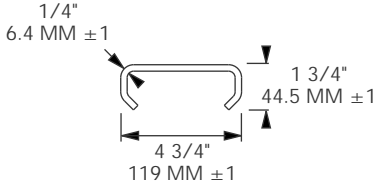
<p>MODEL 2903-2798 WELD ON ISO FLATRACK TYPE</p>  <p>PAINTED BLACK</p>  <p>7 15/16" / 201.5 MM 4 15/16" / 125.6 MM 4 25/32" / 121.75 MM 4 21/32" / 118.4 MM</p>	<p>RAIL FOR SLIDING WINCHES</p>  <p>MODEL 2903-2471 LENGTH: 19 1/2" / 495.3 MM WEIGHT: 10.4 LBS / 4.7 Kg</p> <p>MODEL 2903-2472 LENGTH: 21 1/2" / 546 MM WEIGHT: 11.4 LBS / 5.2 Kg</p> <p>MODEL 2903-2997 LENGTH: 72" / 1,829 MM WEIGHT: 39.4 LBS / 17.9 Kg</p>  <p>1/4" / 6.4 MM ±1 1 3/4" / 44.5 MM ±1 4 3/4" / 119 MM ±1</p>	
<p>WEIGHT: 8.10 LBS / 3.67 Kg</p>	<p>MATERIAL: FAB STEEL FINISH: SELF COLOR</p>	

2900

NOTE: FOR LOAD SECURING ONLY, NOT FOR LIFTING.
ALL WINCH AND STRAP ASSEMBLIES SHOULD BE
INSPECTED FOR FRAYS, CUTS, OR DAMAGED
HARDWARE BEFORE AND AFTER USING.

WORKING LOAD LIMIT (WLL): 5,000 LBS / 2,267 Kg
BREAK STRENGTH (BS): 15,000 LBS / 6,800 Kg
DESIGNED TO MEET OR EXCEED WSTDA T-3 STANDARD.



MODEL 2903-2700
STANDARD

HIGH STRENGTH TIP
GROOVED TIP FOR BETTER GRIP
KNURLED HANDLE GRIPS

Ø13/16" Ø1 5/16" 29 1/2"

CHROME PLATED

NOT TO BE USED AS A CHEATER BAR TO TIGHTEN CHAIN LOAD BINDERS

SUB FOR: ANCRA 42313-17, MULTIPRENS 4101, KINEDYNE 37031
MATERIAL: STEEL
FINISH: CHROME (CH)
WEIGHT: 4.7 LBS / 2.13 Kg

MODEL 2903-6339-B
MODEL 2903-6339-C
COMBINATION BOX END

HIGH STRENGTH TIP
KNURLED HANDLE GRIPS

Ø13/16" Ø1 5/16" 36 1/2"

AVAILABLE BLACK PAINTED OR CHROME

SUB FOR: KINEDYNE 10032 BL, 10033 CH; ANCRA 42313-12 BL; MULTIPRENS 4001 CH, 4003 BL
MATERIAL: STEEL
FINISH: BLACK (BL) OR CHROME (CH)
WEIGHT: 6.75 LBS / 3.06 Kg

2900

MODEL 2903-6345-B
MODEL 2903-6345-C
COMBINATION

HIGH STRENGTH TIP
KNURLED HANDLE GRIPS

Ø13/16" Ø1 5/16" Ø1 5/8" 34"

AVAILABLE BLACK PAINTED OR CHROME

SUB FOR: ANCRA 42313-19 CH, 42313-20 BL; KINEDYNE 37033 CH
MATERIAL: STEEL
FINISH: BLACK (BL) OR CHROME (CH)
WEIGHT: 7.45 LBS / 3.38 Kg

