

SLOTTED CORNER CASTING

MODEL 4002-1432-A

MODEL 4002-1432-B

FOR FOLDING END FLATRACKS

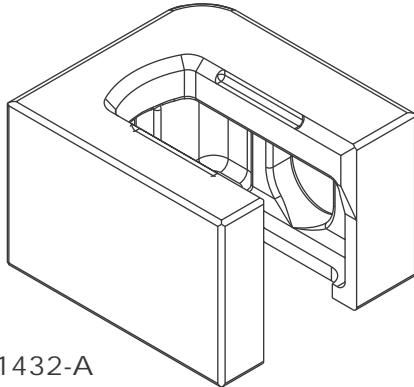

4002-1432-A
LEFT

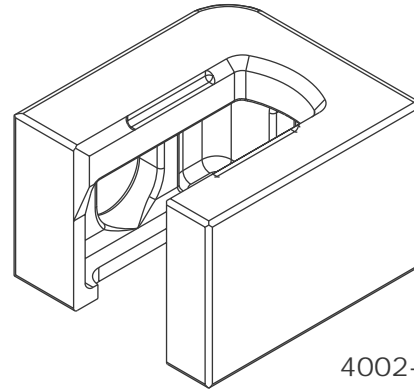

4002-1432-B
RIGHT

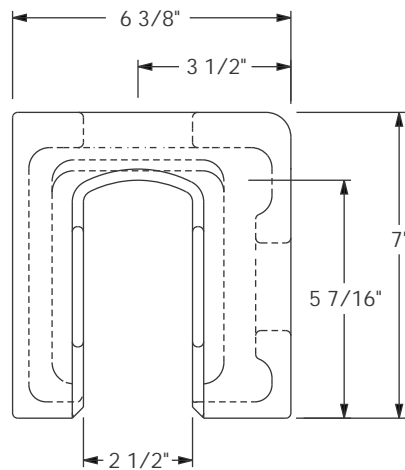

MODEL 4002-1432-A
LEFT CASTING SHOWN,
MODEL 4002-1432-B
RIGHT CASTING IS THE MIRROR OPPOSITE

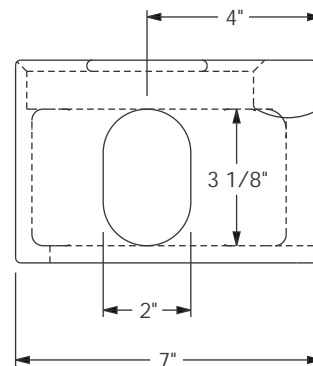
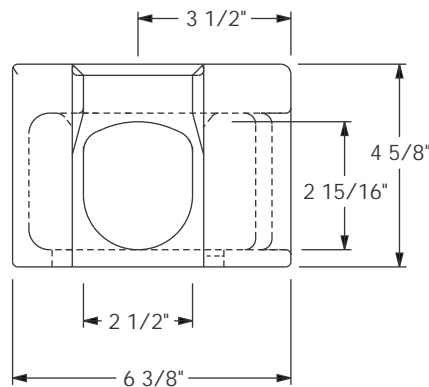

MATERIAL: CAST STEEL PER ISO 1161 REQUIREMENTS
FINISH: MACHINED ALL SIDES AND SHOT BLASTED

4000



TWISTLOCKS FOR FOLDING FLATRACKS

MODEL 4002-1755

SQUARE BOTTOM SIDE SUPPORTS

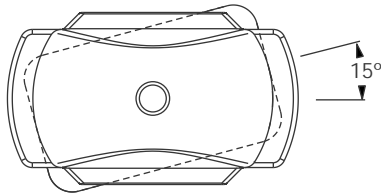

DETENTED LOCKED AND UNLOCKED POSITIONS

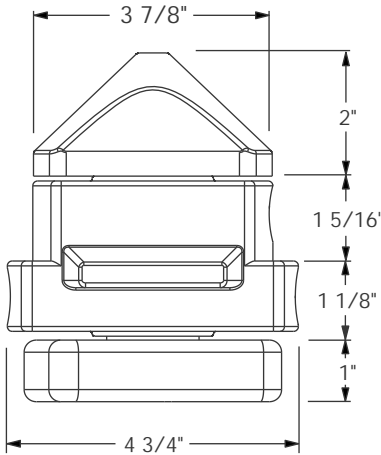

GREASE FITTING
SQUARE BOTTOM
SIDE SUPPORTS
HOLE FOR 1"
ROUND HANDLE

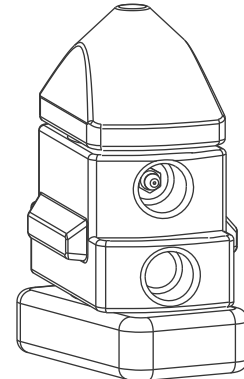
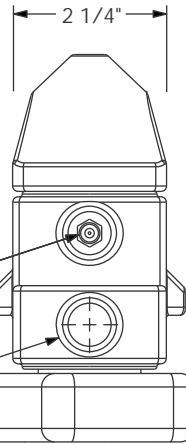

REQUIRES GROOVES ON
CORNER CASTING CHAMFERS

FINISH: PRIMER
WEIGHT: 11.17 LBS / 5.06 Kg

FLIP-OVER TWISTLOCK CONNECTS
STACKED EMPTY FLATRACKS

4000

MODEL 4002-2880

ANGLED BOTTOM SIDE SUPPORTS

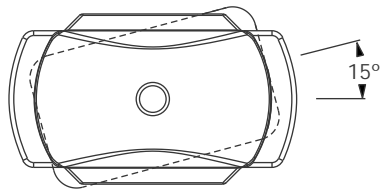

DETENTED LOCKED AND UNLOCKED POSITIONS

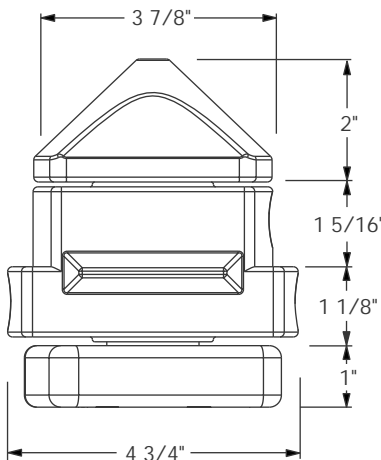

GREASE FITTING
ANGLED BOTTOM
SIDE SUPPORTS
HOLE FOR 1"
ROUND HANDLE

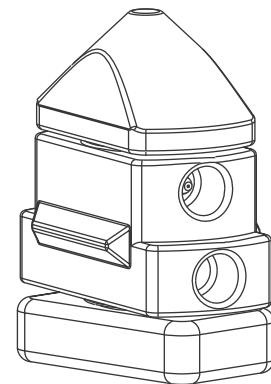
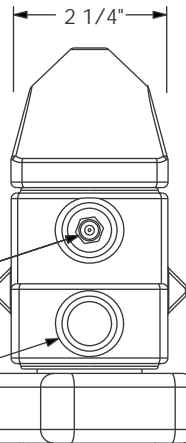

DOES NOT REQUIRE GROOVES ON
CORNER CASTING CHAMFERS

FINISH: PRIMER
WEIGHT: 11.07 LBS / 5.02 Kg

FLIP-OVER TWISTLOCK CONNECTS
STACKED EMPTY FLATRACKS